

STERLING CRANE

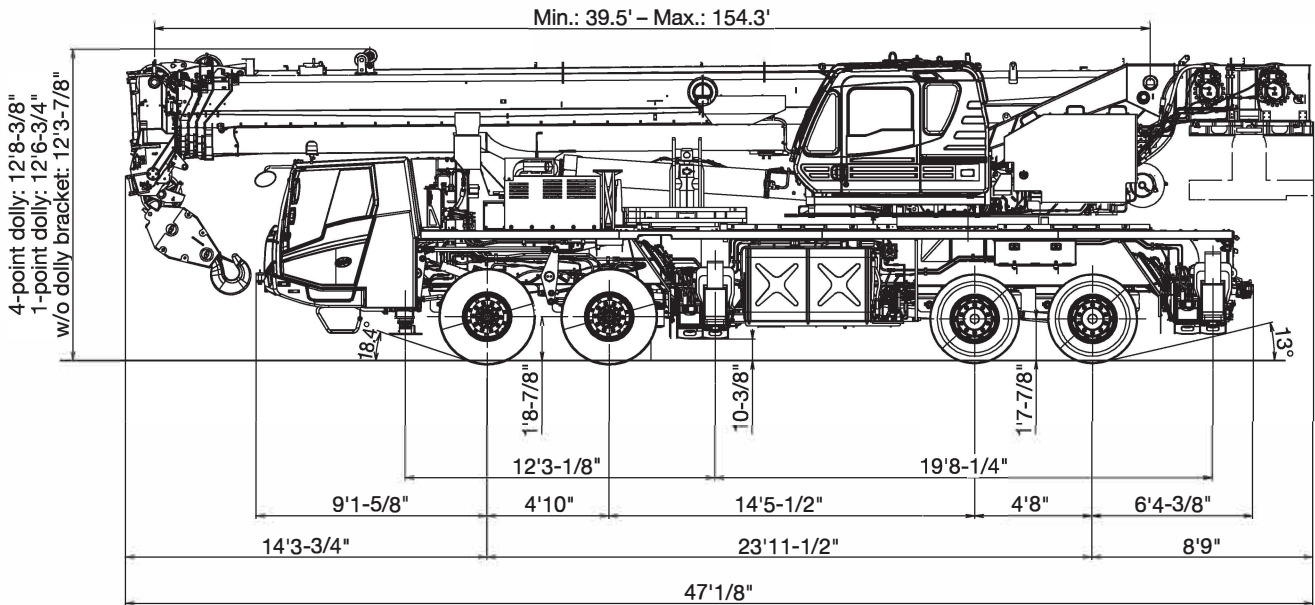

Specifications

Vehicle dimensions



Dimension is with boom angle at +0.3 degree.

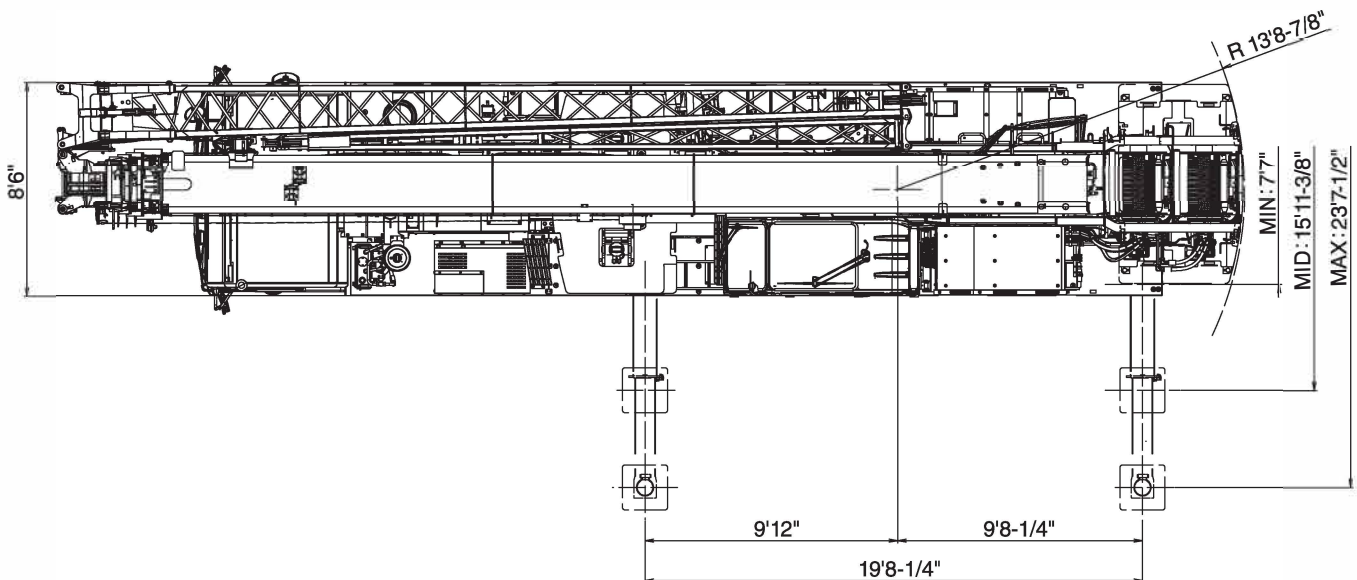

STERLING CRANE



Specifications

Vehicle dimensions

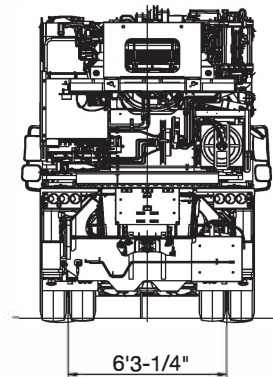
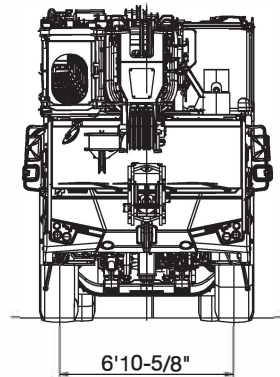

General dimensions

Overall length	approx. 47'-1/8"
Overall width	approx. 8' 6"
Overall height	approx. 12' 3-7/8"
Turning radius: Front tire (curb to curb)	46' 3"

STERLING CRANE



Specifications

Counterweight

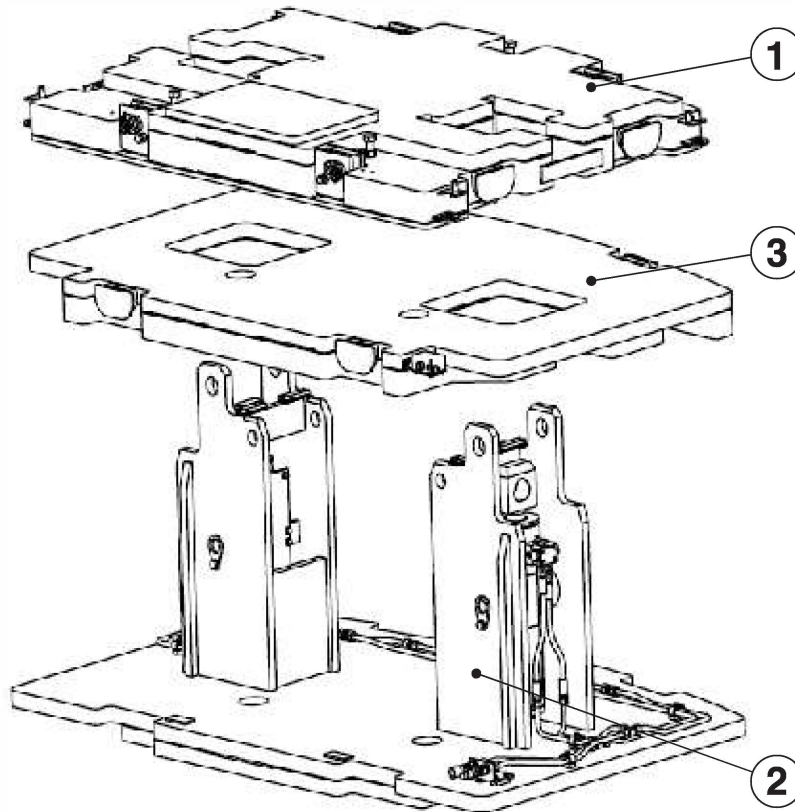

Configurations

	0 lb	6,700 lb	12,400 lb	17,900 lb
① 6,700 lb		1	1	1
② 5,700 lb			1	1
③ 5,500 lb				1

STERLING CRANE



Specifications

Counterweight

1

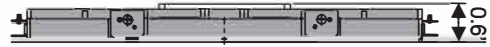
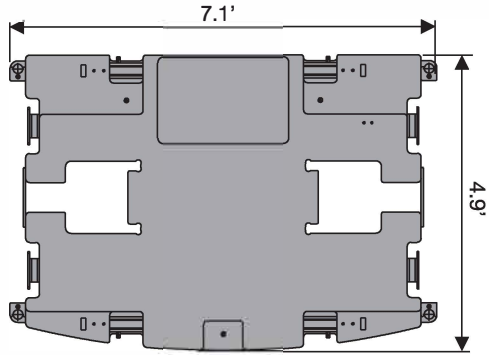

2

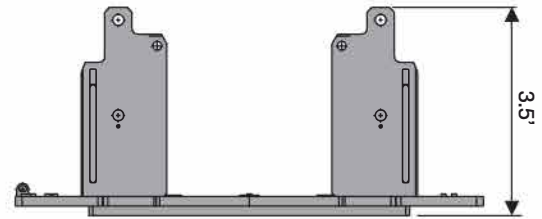
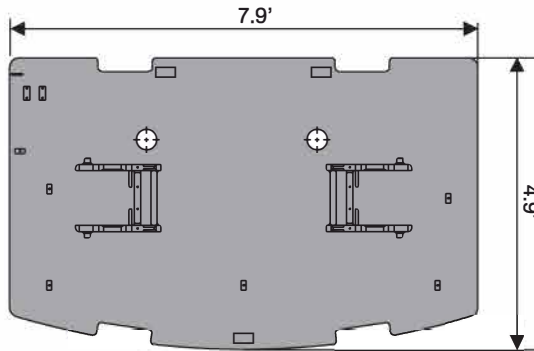

3

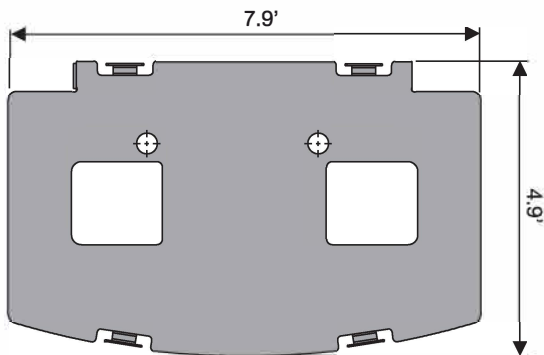









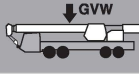
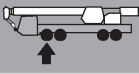
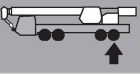

STERLING CRANE





Off-road driving

Axle weight distribution chart

			
	87,450 lb	41,850 lb	45,600 lb
Remove:			
 7.9 ton	-400 lb	-650 lb	250 lb
 Top jib +  Base jib	-2,550 lb	-2,750 lb	200 lb
Single top	-100 lb	-200 lb	100 lb
Add:			
 7.9 ton (stowed on the carrier)	400 lb	450 lb	-50 lb
 55 ton	1,450 lb	2,500 lb	-1,050 lb
 6,700 lb on upper	6,700 lb	-2,900 lb	9,600 lb
 6,700 lb on upper + 5,700 lb on carrier deck	12,400 lb	1,200 lb	11,200 lb
 6,700 lb on upper + 11,200 lb on carrier deck	17,900 lb	5,150 lb	12,750 lb

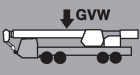
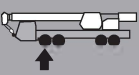
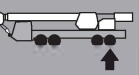
Axle weight distribution equipped with dolly

				
	87,050 lb	33,700 lb	38,500 lb	14,850 lb
without 7.9 ton hook – dolly weight is not included				

Speeds



Max. traveling speed: 65 mph