

# STERLING CRANE

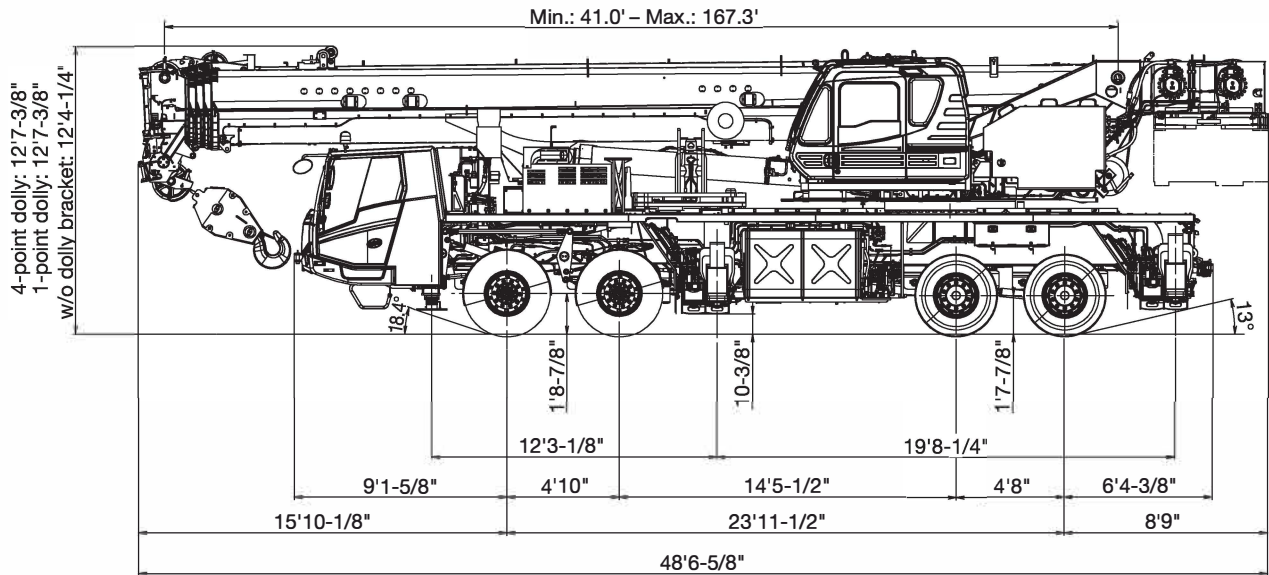

## Specifications

### Vehicle dimensions



Dimension is with boom angle at +0.1 degree.

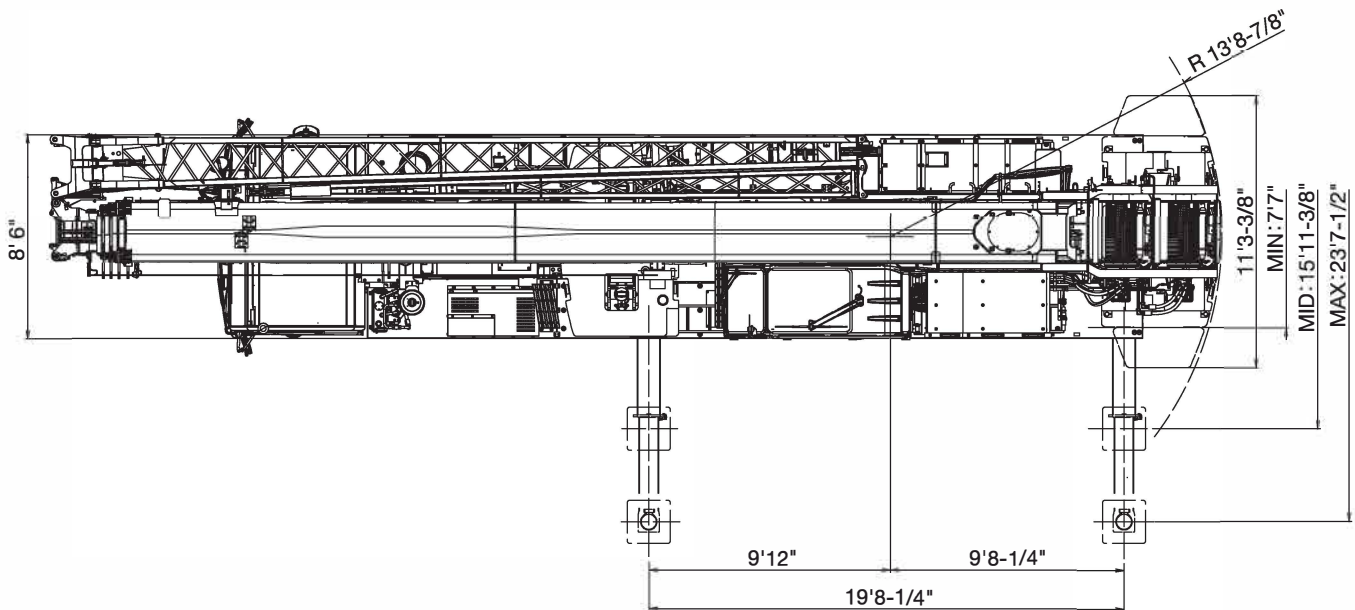

# STERLING CRANE



## Specifications

### Vehicle dimensions

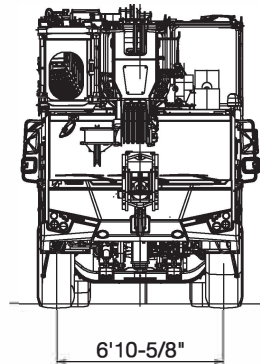
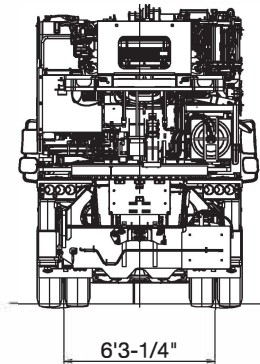

### General dimensions

Overall length	approx. 48' 6-5/8"
Overall width	approx. 8' 6"
Overall height	approx. 12' 4-1/4"
Turning radius: Front tire (curb to curb)	46' 3"

# STERLING CRANE



## Specifications

### Counterweight

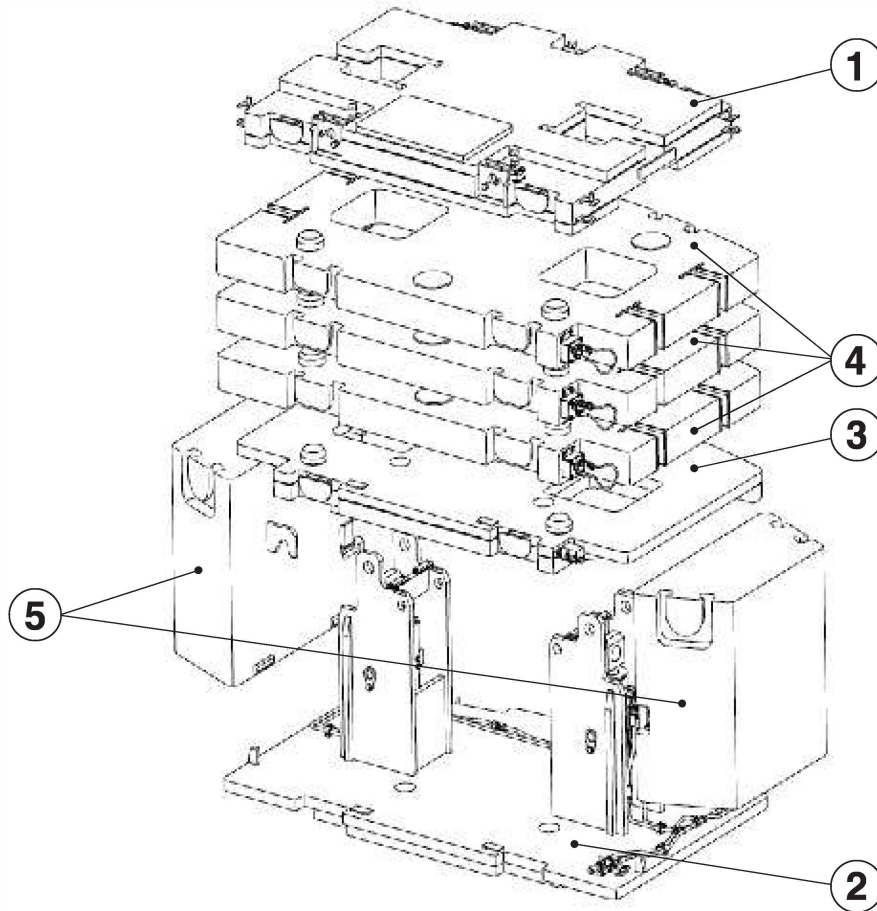

### Configurations

	0 lb	7,700 lb	12,800 lb	17,900 lb	25,400 lb	33,000 lb	40,600 lb	55,100 lb
① 7,700 lb		1	1	1	1	1	1	1
② 5,100 lb			1	1	1	1	1	1
③ 5,100 lb				1	1	1	1	1
④ 7,550 lb					1	2	3	3
⑤ 7,300 lb								2

# STERLING CRANE



## Specifications

### Counterweight

1

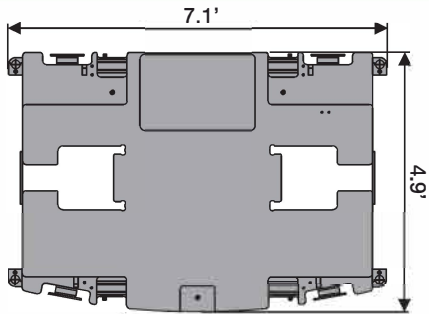

2

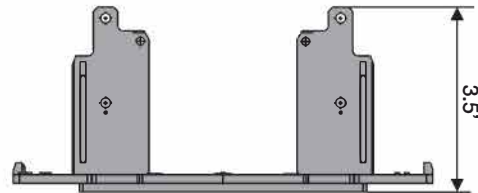
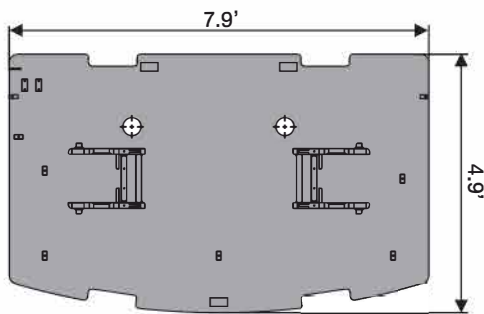

3

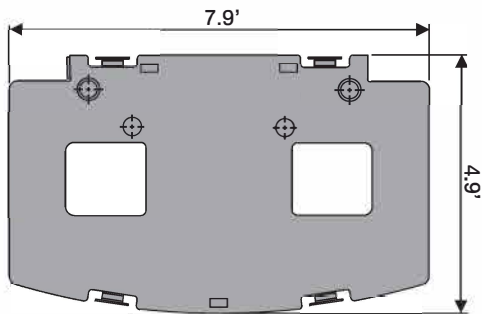

4

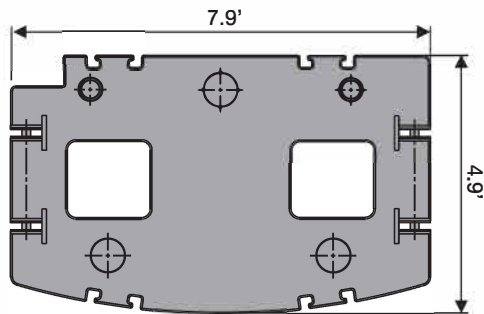

5

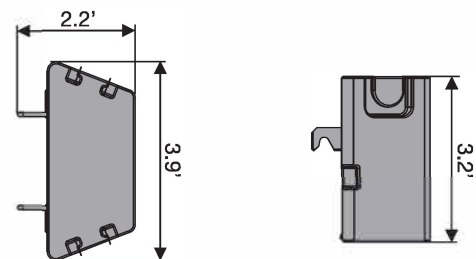









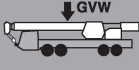
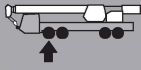
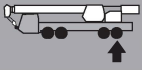

# STERLING CRANE





## Off-road driving

### Axle weight distribution chart

			
	89,900 lb	44,800 lb	45,100 lb
<b>Remove:</b>			
 7.9 ton	-400 lb	-650 lb	250 lb
 Top jib +  Base jib	-2,550 lb	-2,950 lb	400 lb
Single top	-100 lb	-200 lb	100 lb
<b>Add:</b>			
 7.9 ton (stowed on carrier deck)	400 lb	450 lb	-50 lb
 55 ton	1,450 lb	2,500 lb	-1,050 lb
 7,700 lb on upper	7,700 lb	-3,450 lb	11,150 lb
 7,700 lb on upper + 5,100 lb on carrier deck	12,800 lb	200 lb	12,600 lb
 7,700 lb on upper + 10,200 lb on carrier deck	17,900 lb	3,850 lb	14,050 lb

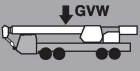
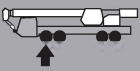
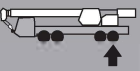
### Axle weight distribution equipped with dolly

				
 without 7.9 ton hook – dolly weight is not included	89,500 lb	34,100 lb	38,800 lb	16,600 lb

### Speeds

 Max. traveling speed: 65 mph