

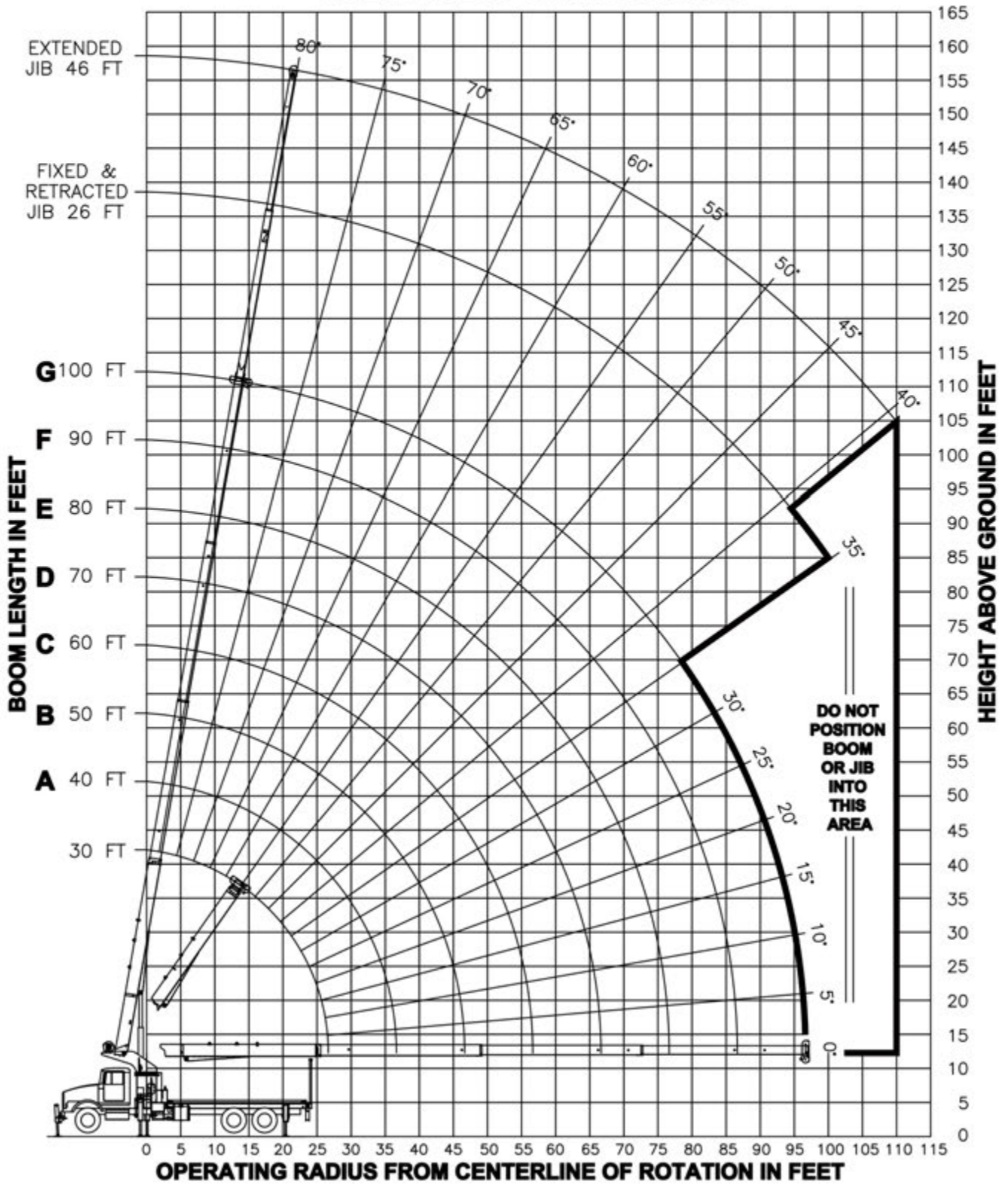

RANGE DIAGRAM - FULL SPREAD CONFIGURATION -



STERLING CRANE



**USE THIS CHART ONLY
WHEN OUTRIGGERS
AND STABILIZERS ARE
FULLY EXTENDED**

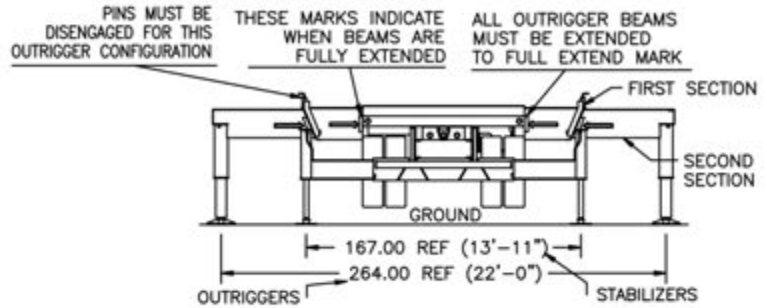

- FULL SPREAD OUTRIGGER CONFIGURATION -

MAIN BOOM LMI CODE 1																	
LOAD RADIUS (FT)	30 FT		40 FT (A)		50 FT (B)		60 FT (C)		70 FT (D)		80 FT (E)		90 FT (F)		100 FT (G)		LOAD RADIUS (FT)
	LOADED BOOM ANGLE (DEG)	LOAD CAPACITY (LBS)	LOADED BOOM ANGLE (DEG)	CODE 1 LOAD CAPACITY (LBS)	LOADED BOOM ANGLE (DEG)	LOAD CAPACITY (LBS)	LOADED BOOM ANGLE (DEG)	LOAD CAPACITY (LBS)	LOADED BOOM ANGLE (DEG)	LOAD CAPACITY (LBS)	LOADED BOOM ANGLE (DEG)	LOAD CAPACITY (LBS)	LOADED BOOM ANGLE (DEG)	LOAD CAPACITY (LBS)	LOADED BOOM ANGLE (DEG)	LOAD CAPACITY (LBS)	
5	77	60000															5
8	70.5	38800															8
10	66.5	33900	73	25000	77	25000											10
12	62	29830	70	25000	74.5	25000	78	25000									12
15	55	25700	65.5	23930	71	22710	75	21850	77.5	20190	79.5	16860					15
20	42	20350	57	19060	64.5	17980	70	17550	73.5	16930	76	14660	78.5	12470	80	10500	20
25	22	15880	47.5	16030	58	15140	64.5	14410	69	13840	72.5	12850	75	11080	77	9580	25
30			36	13350	50.5	12830	59	12200	64.5	11670	68.5	11250	72	9770	74	8540	30
35			19	10360	42.5	10630	53	10530	60	10060	65	9670	68.5	8630	71	7770	35
40					32.5	8240	46.5	8390	55	8490	60.5	8560	65.5	7910	68	6900	40
45					17.5	6520	39	6690	49.5	6780	56.5	6850	61.5	6900	65	6000	45
50							30	5410	43.5	5510	51.5	5580	57.5	5630	61.5	5250	50
55							16	4410	36.5	4520	46.5	4590	53.5	4640	58	4630	55
60									28	3730	41	3800	49	3850	54.5	3890	60
65									15.5	3080	35	3160	44.5	3210	50.5	3250	65
70											27	2620	39	2670	46.5	2710	70
75											15	2160	33.5	2220	42	2260	75
80													26	1830	37.5	1870	80
85													14.5	1480	32	1530	85
90															25	1230	90
95															14	960	95
	490 LBS		370 LBS		300 LBS		250 LBS		210 LBS		190 LBS		170 LBS		150 LBS		FIXED JIB
	730 LBS		550 LBS		440 LBS		370 LBS		320 LBS		280 LBS		250 LBS		220 LBS		TELE JIB

JIB LOAD CAPACITIES

LOAD RADIUS (FT) REF	26 FT FIXED JIB		26 FT TELE JIB		46 FT TELE JIB		LOAD RADIUS (FT) REF
	LOADED BOOM ANGLE (DEG)	CODE 2 LOAD CAPACITY (LBS)	LOADED BOOM ANGLE (DEG)	CODE 3 LOAD CAPACITY (LBS)	LOADED BOOM ANGLE (DEG)	CODE 4 LOAD CAPACITY (LBS)	
25	80	5300	80	5100			25
30	78	5300	78	5100	79.5	3050	30
35	76	5000	76	4800	78	3050	35
40	73.5	4650	73.5	4380	76.5	3050	40
45	71.5	4250	71.5	3980	74.5	3050	45
50	69	3890	69	3610	73	3050	50
55	66.5	3560	66.5	3280	71	2930	55
60	64	3270	64	2980	69	2690	60
65	61.5	2950	61.5	2600	66.5	2470	65
70	58.5	2610	58.5	2270	64.5	2260	70
75	55.5	2320	55.5	1970	62.5	2080	75
80	53	2010	53	1710	60	1890	80
85	49.5	1670	49.5	1380	57.5	1670	85
90	46.5	1370	46.5	1080	55	1470	90
95	43	1110	43	810	52.5	1290	95
100	39	880	39	580	49.5	1050	100
105					46.5	840	105
110					43.5	650	110

DEDUCTIONS FROM MAIN BOOM CAPACITIES FOR STOWED JIB



RANGE DIAGRAM - INTERMEDIATE SPREAD CONFIGURATION - (MID EXTEND)

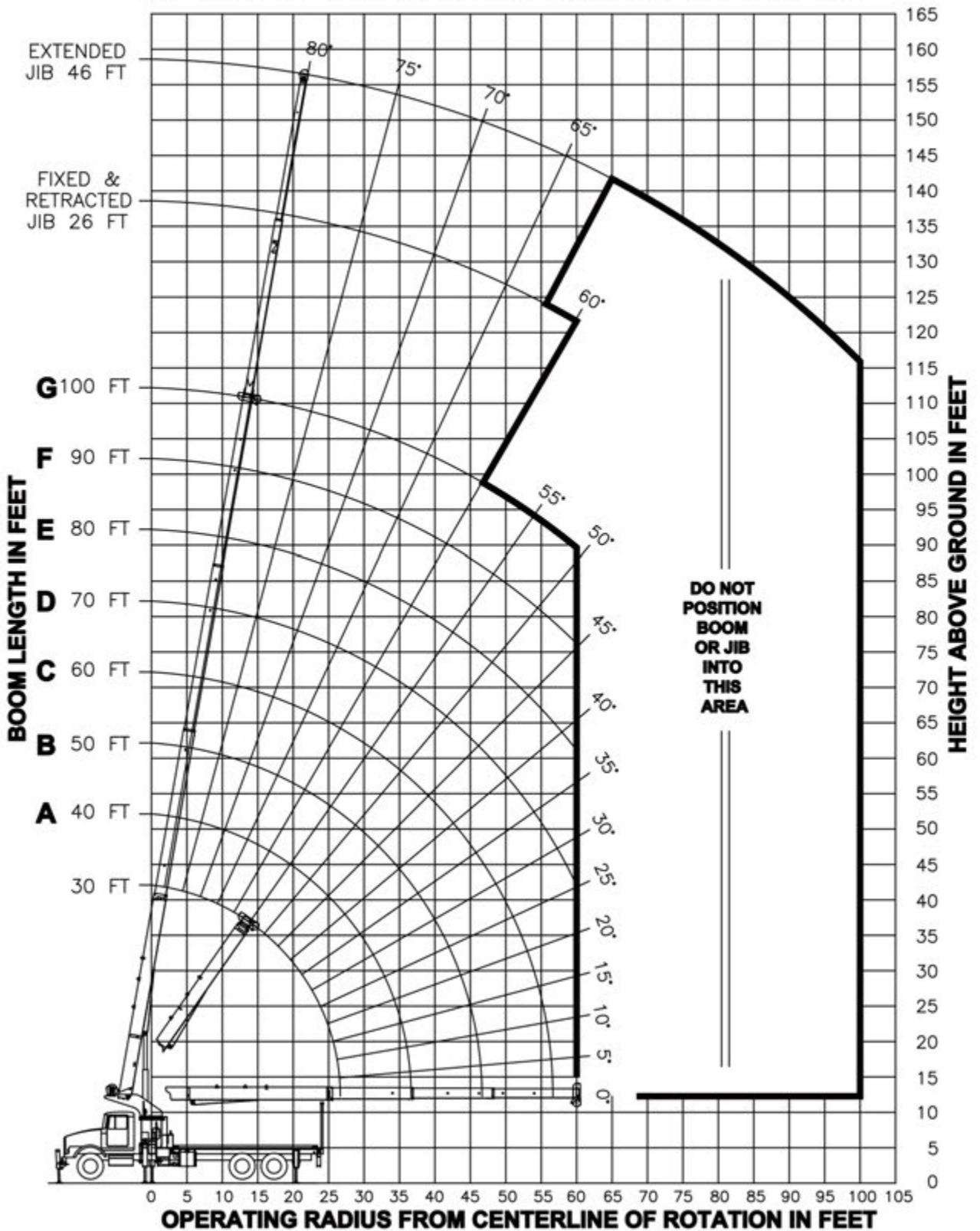

NOTE: LIFTING PERSONNEL WITH CRANE IN THIS OUTRIGGER CONFIGURATION IS STRICTLY PROHIBITED. USE ONLY FULLY EXTENDED OUTRIGGER CONFIGURATION WHEN LIFTING PERSONNEL.

STERLING CRANE



USE THIS CHART ONLY WHEN FRONT OUTRIGGERS ARE IN THE INTERMEDIATE POSITION AND STABILIZERS ARE FULLY EXTENDED

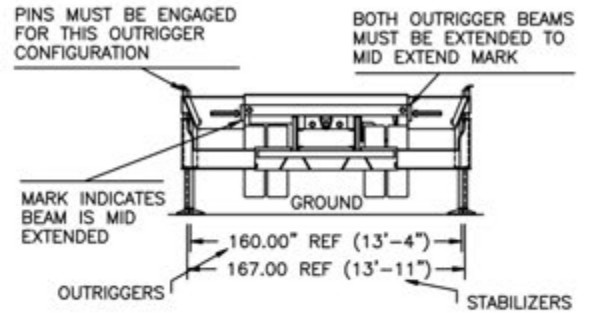

- INTERMEDIATE SPREAD CONFIGURATION - (MID EXTEND)

MAIN BOOM LMI CODE 9																	
LOAD RADIUS (FT)	30 FT		40 FT (A)		50 FT (B)		60 FT (C)		70 FT (D)		80 FT (E)		90 FT (F)		100 FT (G)		LOAD RADIUS (FT)
	LOADED BOOM ANGLE (DEG)	LOAD CAPACITY (LBS)	LOADED BOOM ANGLE (DEG)	CODE 1 LOAD CAPACITY (LBS)	LOADED BOOM ANGLE (DEG)	LOAD CAPACITY (LBS)	LOADED BOOM ANGLE (DEG)	LOAD CAPACITY (LBS)	LOADED BOOM ANGLE (DEG)	LOAD CAPACITY (LBS)	LOADED BOOM ANGLE (DEG)	LOAD CAPACITY (LBS)	LOADED BOOM ANGLE (DEG)	LOAD CAPACITY (LBS)	LOADED BOOM ANGLE (DEG)	LOAD CAPACITY (LBS)	
5	77	60000															5
8	70.5	38800															8
10	66.5	33900	73	25000	77	25000											10
12	62	29830	70	25000	74.5	25000	78	25000									12
15	55	22680	65.5	23170	71	22710	75	21850	77.5	20190	79.5	16860					15
20	42	12710	57	13130	64.5	13360	70	13510	73.5	13610	76	13690	78.5	12470	80	10500	20
25	22	8140	47.5	8560	58	8770	64.5	8910	69	9000	72.5	9070	75	9120	77	9170	25
30			36	5940	50.5	6150	59	6280	64.5	6360	68.5	6430	72	6480	74	6520	30
35			19	4220	42.5	4440	53	4570	60	4660	65	4720	68.5	4760	71	4800	35
40					32.5	3250	46.5	3380	55	3460	60.5	3520	65.5	3570	68	3600	40
45					17.5	2350	39	2490	49.5	2580	56.5	2640	61.5	2680	65	2710	45
50							30	1800	43.5	1890	51.5	1950	57.5	2000	61.5	2030	50
55							16	1250	36.5	1350	46.5	1410	53.5	1450	58	1490	55
60									28	900	41	970	49	1010	54.5	1050	60
65																	65
70																	70
75																	75
80																	80
85																	85
90																	90
95																	95
	490 LBS		370 LBS		300 LBS		250 LBS		210 LBS		190 LBS		170 LBS		150 LBS		FIXED JIB
	730 LBS		550 LBS		440 LBS		370 LBS		320 LBS		280 LBS		250 LBS		220 LBS		TELE JIB

JIB LOAD CAPACITIES

LOAD RADIUS (FT) REF	26 FT FIXED JIB		26 FT TELE JIB		46 FT TELE JIB		LOAD RADIUS (FT) REF
	LOADED BOOM ANGLE (DEG)	CODE 10 LOAD CAPACITY (LBS)	LOADED BOOM ANGLE (DEG)	CODE 11 LOAD CAPACITY (LBS)	LOADED BOOM ANGLE (DEG)	CODE 12 LOAD CAPACITY (LBS)	
25	80	5300	80	5100			25
30	78	5300	78	5100	79.5	3050	30
35	76	4940	76	4640	78	3050	35
40	73.5	3730	73.5	3420	76.5	3050	40
45	71.5	2830	71.5	2530	74.5	3050	45
50	69	2140	69	1830	73	2350	50
55	66.5	1590	66.5	1290	71	1790	55
60	64	1150	64	840	69	1340	60
65					66.5	960	65
70							70
75							75
80							80
85							85
90							90
95							95
100							100
105							105
110							110

DEDUCTIONS FROM MAIN BOOM CAPACITIES FOR STOWED JIB



RANGE DIAGRAM - FULLY RETRACTED SPREAD CONFIGURATION -

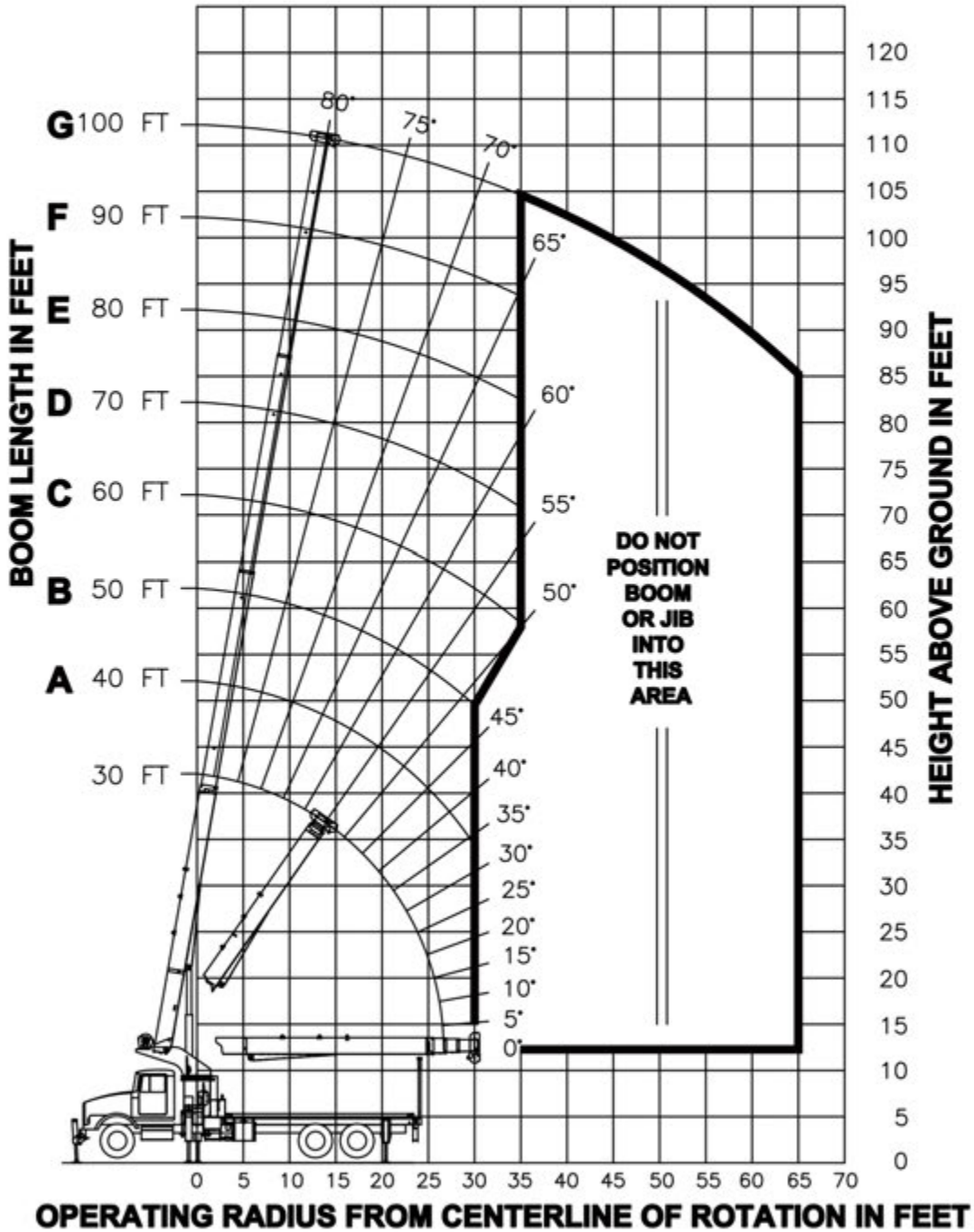

NOTE : LIFTING PERSONNEL WITH CRANE IN THIS OUTRIGGER CONFIGURATION IS STRICTLY PROHIBITED. USE ONLY FULLY EXTENDED OUTRIGGER CONFIGURATION WHEN LIFTING PERSONNEL.

STERLING CRANE



**USE THIS CHART
ONLY WHEN
OUTRIGGERS AND
STABILIZERS ARE
FULLY RETRACTED**

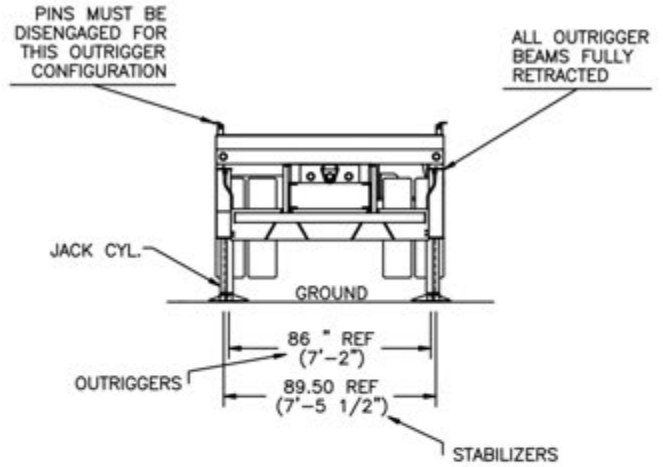

- FULLY RETRACTED SPREAD CONFIGURATION -

MAIN BOOM LMI CODE 13																	
LOAD RADIUS (FT)	30 FT		40 FT (A)		50 FT (B)		60 FT (C)		70 FT (D)		80 FT (E)		90 FT (F)		100 FT (G)		LOAD RADIUS (FT)
	LOADED BOOM ANGLE (DEG)	LOAD CAPACITY (LBS)	LOADED BOOM ANGLE (DEG)	CODE 1 LOAD CAPACITY (LBS)	LOADED BOOM ANGLE (DEG)	LOAD CAPACITY (LBS)	LOADED BOOM ANGLE (DEG)	LOAD CAPACITY (LBS)	LOADED BOOM ANGLE (DEG)	LOAD CAPACITY (LBS)	LOADED BOOM ANGLE (DEG)	LOAD CAPACITY (LBS)	LOADED BOOM ANGLE (DEG)	LOAD CAPACITY (LBS)	LOADED BOOM ANGLE (DEG)	LOAD CAPACITY (LBS)	
5	77	60000															5
8	70.5	25250															8
10	66.5	16190	73	16620	77	16870											10
12	62	11440	70	11820	74.5	12050	78	12200									12
15	55	7430	65.5	7780	71	7980	75	8110	77.5	8210	79.5	8280					15
20	42	3980	57	4320	64.5	4500	70	4620	73.5	4710	76	4770	78.5	4810	80	4850	20
25	22	2110	47.5	2460	58	2650	64.5	2760	69	2840	72.5	2900	75	2940	77	2970	25
30			36	1300	50.5	1490	59	1600	64.5	1680	68.5	1730	72	1770	74	1800	30
35							53	810	60	880	65	940	68.5	980	71	1010	35
40																	40
45																	45
50																	50
55																	55
60																	60
65																	65
70																	70
75																	75
80																	80
85																	85
90																	90
95																	95
	490 LBS	370 LBS	300 LBS	250 LBS	210 LBS	190 LBS	170 LBS	150 LBS	FIXED JIB								
	730 LBS	550 LBS	440 LBS	370 LBS	320 LBS	280 LBS	250 LBS	220 LBS	TELE JIB								

DEDUCTIONS FROM MAIN BOOM CAPACITIES FOR STOWED JIB

STERLING CRANE



ALLOWABLE LINE PULL							WARNING
1 PART LINE	2 PART LINE	3 PART LINE	4 PART LINE	5 PART LINE	6 PART LINE	7 PART LINE	
							<p>ANTI-TWO-BLOCK SYSTEM MUST BE IN GOOD OPERATING CONDITION BEFORE OPERATING CRANE.</p> <p>REFER TO THE OWNER'S MANUAL.</p> <p>KEEP AT LEAST 3 WRAPS OF LOAD LINE ON THE DRUM AT ALL TIMES.</p>
8500 LBS	17000 LBS	25500 LBS	34000 LBS	42500 LBS	51000 LBS	60000 LBS	9/16" 6X25 IWRC (3.5:1 SF) - 29750 LBS MIN BREAKING STRENGTH
7700 LBS	15400 LBS	23100 LBS	30800 LBS	38500 LBS	46200 LBS	53900 LBS	9/16" ROT RESISTANT (5.0:1 SF) - 38500 LBS MIN BREAKING STRENGTH

AREA OF OPERATION

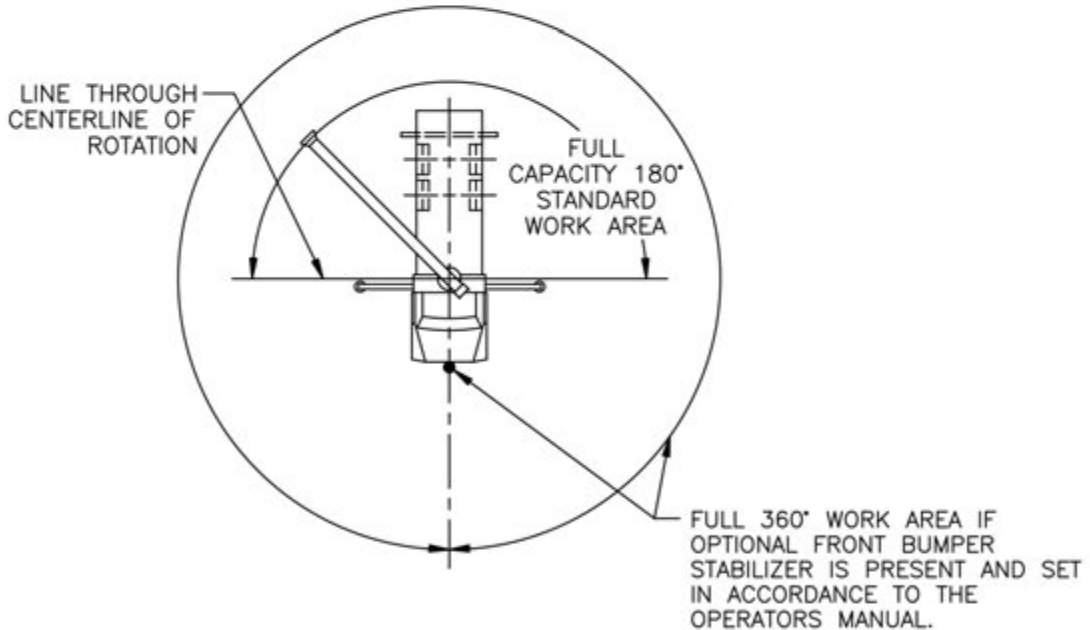

DEDUCTIONS FROM RATED LOADS FOR LOAD HANDLING DEVICES SUPPLIED BY MANITEX

AUXILIARY BLOCK	---	---	---	---	---	---	---	50 LBS
AUXILIARY SHEAVE	---	---	---	---	---	---	---	50 LBS
OVERHAUL BALL	---	---	---	---	---	---	---	SEE OVERHAUL BALL MANUFACTURER NAMEPLATE
LOAD BLOCK	---	---	---	---	---	---	---	SEE BLOCK MANUFACTURER NAMEPLATE
HOSE REEL	---	---	---	---	---	---	---	140 LBS
SWING AROUND JIB	---	---	---	---	---	---	---	SEE LOAD CHART



LMI OPERATING CODES

SETTING	CRANE CONFIGURATION	OUTRIGGER CONFIGURATION
#1	— MAIN BOOM	FULLY EXTENDED
#2	— FIXED JIB	FULLY EXTENDED
#3	— TELESCOPIC JIB—RETRACTED	FULLY EXTENDED
#4	— TELESCOPIC JIB—EXTENDED	FULLY EXTENDED
#5	— PERSONNEL LIFTING PLATFORM ON MAIN BOOM	FULLY EXTENDED
#6	— PERSONNEL LIFTING PLATFORM ON FIXED JIB	FULLY EXTENDED
#7	— PERSONNEL LIFTING PLATFORM ON TELESCOPIC JIB—RETRACTED	FULLY EXTENDED
#8	— PERSONNEL LIFTING PLATFORM ON TELESCOPIC JIB—EXTENDED	FULLY EXTENDED
#9	— MAIN BOOM	INTERMEDIATE
#10	— FIXED JIB	INTERMEDIATE
#11	— TELESCOPIC JIB—RETRACTED	INTERMEDIATE
#12	— TELESCOPIC JIB—EXTENDED	INTERMEDIATE
#13	— MAIN BOOM	FULLY RETRACTED

WARNING

1. THE OPERATOR MUST READ AND UNDERSTAND THE OWNER'S MANUAL BEFORE OPERATING THIS CRANE.
2. POSITIONING OR OPERATION OF CRANE BEYOND AREAS SHOWN ON THIS CHART IS NOT INTENDED OR APPROVED EXCEPT WHERE SPECIFIED IN OWNER'S MANUAL.
3. LOADED BOOM ANGLES AT SPECIFIED BOOM LENGTHS GIVE ONLY AN APPROXIMATION OF THE OPERATING RADIUS. THE BOOM ANGLE BEFORE LOADING SHOULD BE GREATER TO ACCOUNT FOR DEFLECTIONS. DO NOT EXCEED THE OPERATING RADIUS FOR RATED LOADS.
4. THE OPERATING RADIUS SHOWN IN THE JIB RATING CHART IS FOR FULLY EXTENDED BOOM ONLY. WHEN BOOM IS NOT FULLY EXTENDED, USE ONLY LOADED BOOM ANGLE TO DETERMINE LOAD RATING OF JIB.
5. FOR BOOM ANGLES NOT SHOWN ON JIB LOAD RATING CHART, USE RATING OF NEXT LOWER BOOM ANGLE.
6. FOR BOOM LENGTHS NOT SHOWN, USE RATING OF NEXT SHORTER OR LONGER BOOM LENGTH, WHICHEVER IS LESS. FOR RADII NOT SHOWN, USE RATING OF NEXT LONGER RADIUS.
7. CRANE LOAD RATINGS ON OUTRIGGERS ARE BASED ON FREELY SUSPENDED LOADS WITH THE MACHINE LEVELED AND STANDING ON A FIRM UNIFORM SUPPORTING SURFACE. NO ATTEMPT SHALL BE MADE TO MOVE A LOAD HORIZONTALLY ON THE GROUND IN ANY DIRECTION.

STERLING CRANE



WARNING (CONTINUED)

8. PRACTICAL WORKING LOADS DEPEND ON SUPPORTING SURFACE, WIND, AND OTHER FACTORS AFFECTING STABILITY SUCH AS HAZARDOUS SURROUNDINGS, EXPERIENCE OF PERSONNEL, AND PROPER HANDLING, ALL OF WHICH MUST BE TAKEN INTO ACCOUNT BY THE OPERATOR.
9. THE MAXIMUM LOAD WHICH MAY BE TELESCOPED IS LIMITED BY HYDRAULIC PRESSURE, BOOM ANGLE, AND BOOM LUBRICATION. IT IS SAFE TO ATTEMPT TO TELESCOPE ANY LOAD WITHIN THE LIMITS OF THE LOAD RATING CHART.
10. LIFTING OFF THE MAIN BOOM POINT WHILE THE SWING AROUND JIB IS ERECTED IS NOT INTENDED OR APPROVED.

INFORMATION

1. DEDUCTIONS MUST BE MADE FROM RATED LOADS FOR STOWED JIB, OPTIONAL ATTACHMENTS, HOOKS, AND LOADBLOCKS (SEE DEDUCTION CHART). WEIGHTS OF SLINGS AND ALL OTHER LOAD HANDLING DEVICES SHALL BE CONSIDERED A PART OF THE LOAD.
2. LOAD RATINGS ABOVE THE HEAVY LINE ARE STRUCTURALLY LIMITED CAPACITIES. LOAD RATINGS BELOW THE HEAVY LINE ARE STABILITY LIMITED CAPACITIES AND DO NOT EXCEED 85% OF TIPPING.

DEFINITIONS

1. OPERATING RADIUS IS THE HORIZONTAL DISTANCE FROM THE AXIS OF ROTATION TO THE CENTER OF THE VERTICAL HOIST LINE OR TACKLE WITH LOAD APPLIED.
2. LOADED BOOM ANGLE AS SHOWN IN THE COLUMN HEADED BY \angle , IS THE INCLUDED ANGLE BETWEEN THE HORIZONTAL AND LONGITUDINAL AXES OF THE BOOM BASE AFTER LIFTING RATED LOAD AT RATED RADIUS.