

# STERLING CRANE



## LIFTING CHARTS - Carry Decks

### BRODERSON MODEL IC-200-2H/3H - 15 TON CAPACITY

CAPACITIES APPLY TO OPERATION ON FIRM LEVEL SURFACE							
LOAD RADIUS FEET	MAIN BOOM OR EXTENSION CAPACITIES IN POUNDS						
	360° ROTATION		OVER FRONT				
	ON RUBBER	ON OUTRIGGERS	ON RUBBER	ON OUTRIGGERS			
6	16200	30000	17000	30000			
8	13200	24000	13800	24000			
10	10600	19800	11500	19800			
12	7800	16100	9600	16100			
14	6100	13500	7900	13500			
16	4900	11200	6300	11200			
18	4000	10000	5100	10000			
20	3300	8800	4300	8800			
22	2800	7700	3600	7800			
24	2350	6600	3000	6900			
26	2050	5750	2600	6200			
28	1800	5150	2300	5700			
30	1600	4650	2100	5300			
32	1400	4200	1850	4900			
36	1150	3400	1500	4200			
40	900	3050	1200	3600			
44	650	2600	950	3100			
48	450	2200	750	2700			
51	250	1900	600	2400			
15' BOOM EXT. ANGLE	15-FOOT BOOM EXTENSION - STRAIGHT OR OFFSET						
	MAIN BOOM ANGLE						
	0°	15°	30°	40°	50°	60°	70°
0°	---	3100	3450	3900	4650	6000	7500
15°	---	3000	3100	3300	3650	4250	5200
30°	---	---	3000	3050	3200	3450	3900

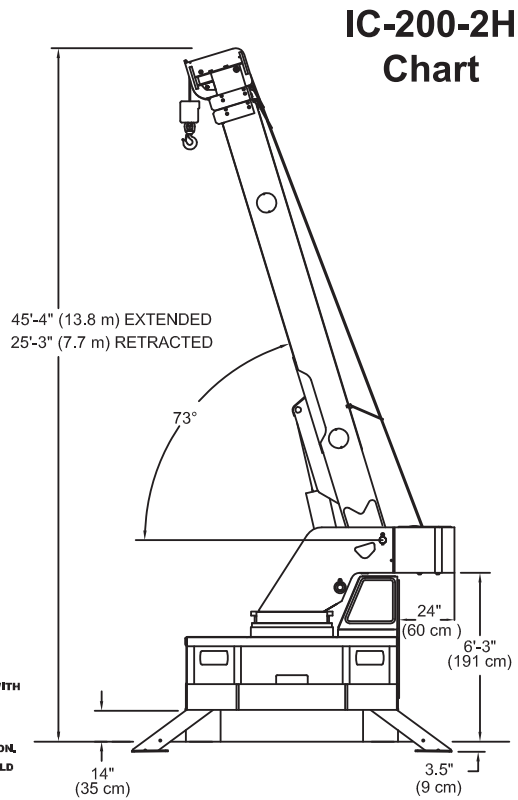

LOAD RADIUS IS THE HORIZONTAL DISTANCE FROM THE CENTER OF ROTATION OF THE UNLOADED CRANE TO THE VERTICAL LOAD LINE WITH THE LOAD APPLIED.

EXCEEDING CAPACITY RATINGS OR APPLYING SIDE LOADS TO THE BOOM OR BOOM EXTENSION IS MISUSE, IS HAZARDOUS, AND VOIDS WARRANTY.

CAUTION BOOM EXTENSION LOADS MUST NOT EXCEED MAIN BOOM CAPACITY. DO NOT PICK AND CARRY WITH LOADS ON BOOM EXTENSION. CAPACITIES ON OUTRIGGERS ARE 85% OF TIPPING LOADS. CAPACITIES ON RUBBER ARE 75% OF TIPPING LOADS. CAPACITIES BELOW BOLD LINE ARE LIMITED BY TIPPING. OTHER CAPACITIES ARE LIMITED BY STRUCTURAL OR HYDRAULIC CAPABILITY.

BOOM EXTENSION DEDUCT: 400 LBS. WHEN STOWED ON MAIN BOOM.

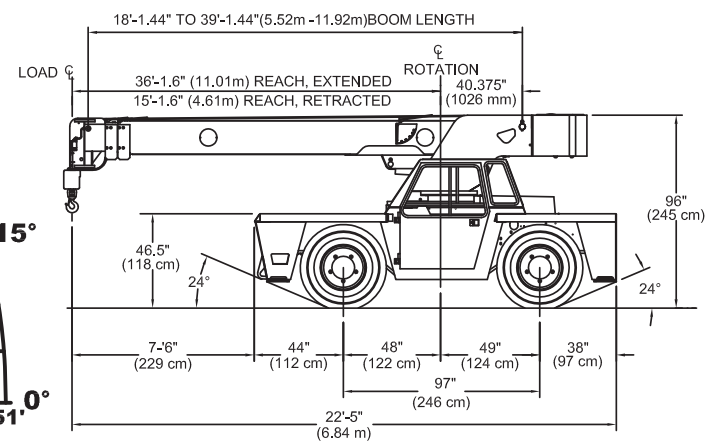
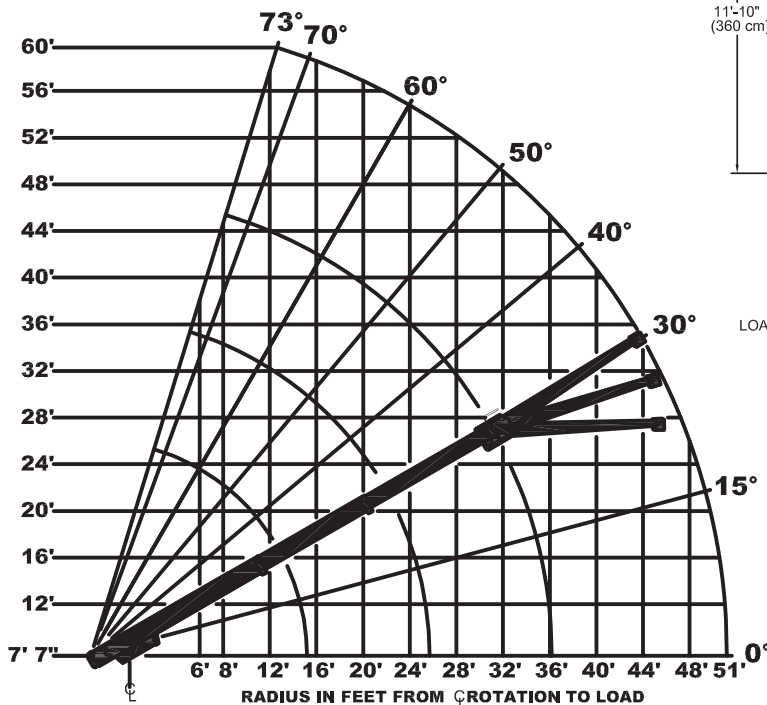
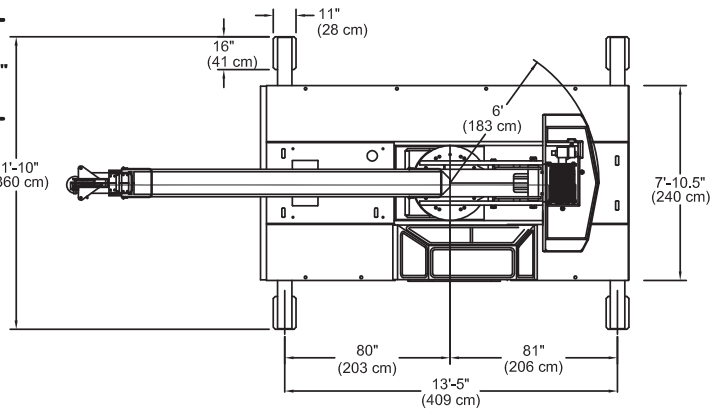
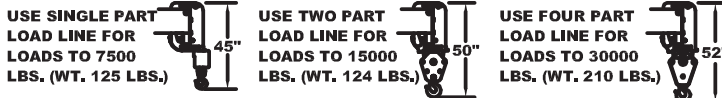

# STERLING CRANE

CAPACITIES IN POUNDS FOR OPERATION ON FIRM LEVEL SURFACE								
LOAD RADIUS FEET	MAIN BOOM ONLY				BOOM EXTENSION			
	ON RUBBER		ON OUTRIGGERS		ON RUBBER		ON OUTRIGGERS	
	360°	FRONT	360°	FRONT	360°	FRONT	360°	FRONT
6	16000	16400	30000	30000	---	---	---	---
8	12500	13000	22400	22400	---	---	---	---
10	10000	10500	18500	18500	7500	7500	7500	7500
12	8050	8700	15700	15700	7500	7500	7500	7500
14	6500	7200	13500	13500	7500	7500	7500	7500
16	5300	6200	10800	10800	6150	7500	7500	7500
18	4450	5400	9550	9550	5000	6450	7500	7500
20	3700	4700	8550	8550	4200	5400	7500	7500
22	3150	4200	7700	7700	3550	4650	6850	6850
24	2650	3700	6950	6950	3050	4000	6250	6250
26	2300	3200	6300	6300	2650	3500	5750	5750
28	1950	2800	5550	5800	2300	3100	5300	5300
30	1700	2450	4800	5300	2000	2700	4900	4900
32	1450	2150	4200	4900	1700	2400	4550	4550
34	1250	1850	3700	4500	1500	2100	4250	4250
38	900	1300	2950	3850	1150	1650	3500	3750
42	650	950	2400	3350	850	1300	2950	3350
46	400	650	1850	2900	600	1050	2450	2950
50	0	550	1750	2500	400	800	2050	2600
54	---	---	---	---	0	600	1700	2300
58	---	---	---	---	0	400	1350	2000
62	---	---	---	---	0	300	1150	1750
66	---	---	---	---	0	0	900	1500
BOOM EXT. ANGLE	BOOM EXTENSION - STRAIGHT OR OFFSET							
	MAIN BOOM ANGLE							
	0°	15°	30°	40°	50°	60°	70°	
	3000	3100	3450	3900	4650	6000	7500	
15°	---	3000	3000	3000	3700	5000		
30°	---	---	2500	2500	2600	3100	3800	

LOAD RADIUS IS THE HORIZONTAL DISTANCE FROM THE CENTER OF ROTATION OF THE UNLOADED CRANE TO THE VERTICAL LOAD LINE WITH THE LOAD APPLIED.

EXCEEDING CAPACITY RATINGS OR APPLYING SIDE LOADS TO THE BOOM OR BOOM EXTENSION IS MISUSE, IS HAZARDOUS, AND VOIDS WARRANTY.

CAUTION BOOM EXTENSION LOADS MUST NOT EXCEED MAIN BOOM CAPACITY. DO NOT PICK AND CARRY WITH LOADS ON BOOM EXTENSION. CAPACITIES ON OUTRIGGERS ARE 85% OF TIPPING LOADS. CAPACITIES ON RUBBER ARE 75% OF TIPPING LOADS. CAPACITIES BELOW BOLD LINE ARE LIMITED BY TIPPING. OTHER CAPACITIES ARE LIMITED BY STRUCTURAL OR HYDRAULIC CAPABILITY. BOOM EXTENSION DEDUCT: 400 LBS. WHEN STOWED ON MAIN BOOM.

## IC-200-3H Chart

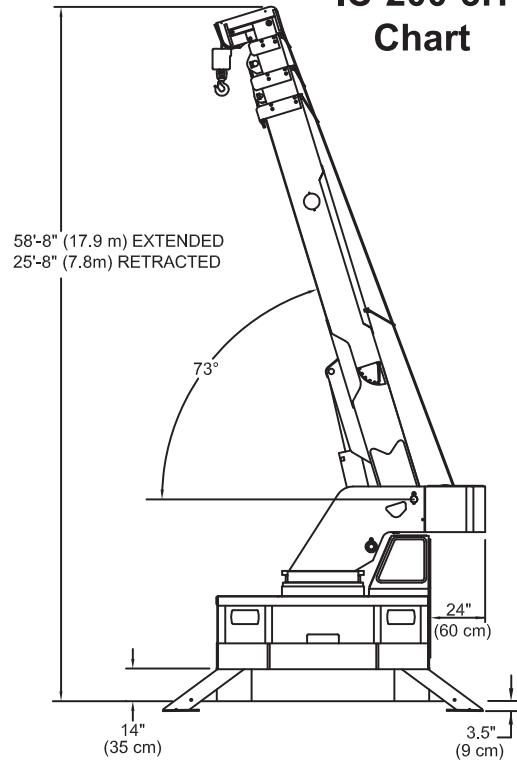

USE SINGLE PART LOAD LINE FOR LOADS TO 7500 LBS. (WT. 125 LBS.)

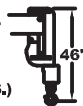

USE TWO PART LOAD LINE FOR LOADS TO 15000 LBS. (WT. 200 LBS.)



USE FOUR PART LOAD LINE FOR LOADS TO 30000 LBS. (WT. 210 LBS.)

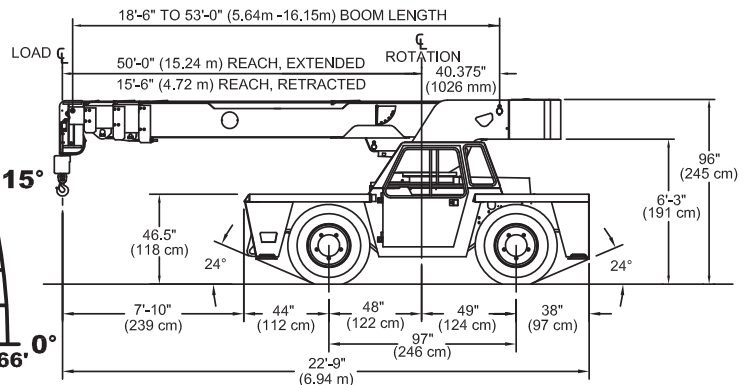
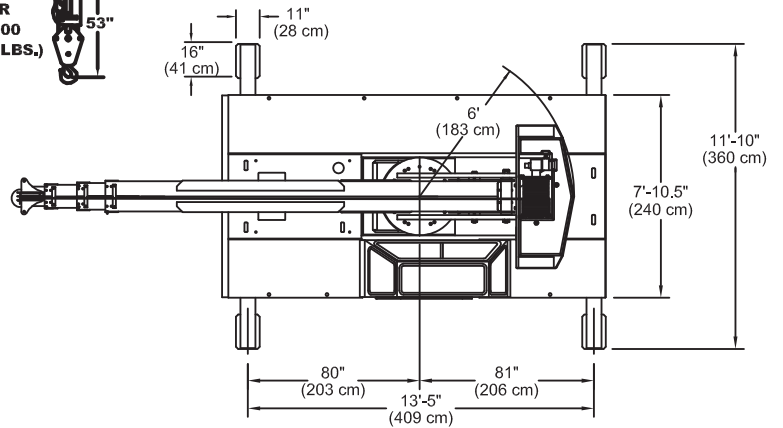
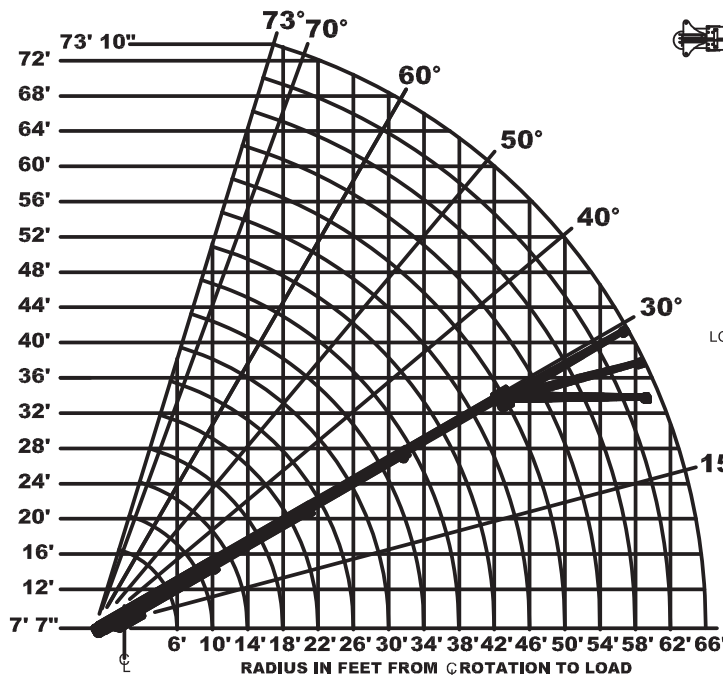

# STERLING CRANE

## GENERAL:

<b>Weight:</b>	<b>IC-200-2H</b> 28,500 lbs (12,940 kg)	<b>IC-200-3H</b> 31,080 lbs (14,110 kg)
<b>Boom Movement:</b>		
<b>Rotation</b>	Continuous	Continuous
<b>Elevation</b>	0° to 73°	0° to 73°
<b>Extension</b>	21' 0" (6.4m)	34' 6" (10.5m)
<b>Boom Speeds:</b>		
<b>Rotation</b>	1.9 RPM	1.8 RPM
<b>Elevation</b>	20 sec.	20 sec.
<b>Extension</b>	36 sec.	55 sec.
<b>Gradeability:</b>	54% (28 Degrees)	
<b>Turning Radius:</b>	14' 5" (4.42m)	

## ENGINE:

	<b>Standard</b>	<b>Optional</b>
<b>Make</b>	GM*	Cummins**
<b>Model</b>	4.3L V-6	QSB3.3
<b>Type</b>	Gasoline	Turbo-Diesel
<b>No. Cyl.</b>	6	4
<b>Displacement</b>	262 CID (4.3L)	199 CID (3.3L)
<b>HP @ Gov. Speed</b>	93 H.P. (69 kW)	100 H.P. (75 kW)
<b>Fuel Tank Capacity</b>	30 Gallons (113L)	

\*Electronic Fuel Injection with Dual Fuel & Engine Management System, US EPA Tier 2

\*\*Charge Air Cooled & Grid Heater US EPA Tier 4i Emissions Certified

## TRANSMISSION:

Powershift transmission with 4-speeds forward and reverse. Provides powershifts at any engine speed in any gear. All shifting is done with a single lever electrical control mounted on the steering column. Equipped with torque converter and transmission oil cooler. Torque converter has stall ratio of 2.2:1.

Gear Ratio:

First	5.72:1	Second	3.23:1
Third	1.77:1	Fourth	1.00:1

## AXLES:

### Front Axle:

Planetary drive/steer front axle with 15.78 to 1.0 ratio. Differential equipped with "limited slip" feature. Front axle mounted rigidly to frame.

Gear	Travel Speed	Drawbar Pull*
First	3 MPH	17,000*
Second	5 MPH	8,900*
Third	10 MPH	5,100*
Fourth	18 MPH	2,700*

\*Drawbar pull is calculated for GM 4.3L engine.

### Rear Axle:

#### Standard (2-Wheel Drive):

Steering axle with 1-1/2 degree oscillation in either direction.

#### Optional (4-Wheel Drive):

Planetary drive/steer axle with 24.98 to 1.0 ratio. Differential is not "limited slip" in rear axle. 1-1/2 degree oscillation in either direction. Axle ratio compatible with 4-wheel drive transmission output for front axle match. Transmission equipped with electrohydraulic control for shifting between 2-wheel drive and 4-wheel drive.

## STEERING:

Full hydraulic steering unit with two 3-inch (7.6 cm) cylinders attached to each axle. Allows limited steering when engine is not running. A switch on the control panel is used to select rear-wheel steering, four-wheel steering or crab steering. Electronic sensors and control box automatically align the steering when a new mode is selected.

## BRAKES:

**Service:** Split-system, 4-wheel hydraulic-boosted multiple-plate wet disc brakes.

**Parking:** Hand lever actuated disc-type parking brake on transmission.

**TIRES:** 15x22.5, 16-ply rating.

## OPERATOR COMPARTMENT:

Provides one-position access to all chassis and crane functions. Includes adjustable operator's seat, retracting seat belts, fire extinguisher and bubble level.

## CHASSIS:

### Cargo Deck:

66 square feet (6 m<sup>2</sup>) of deck area. 17,000 lbs (7,700 kg) capacity on deck when load is centered over or between axles. Steps located on front corners.

### Lifting Rings:

Lifting rings at each corner of load deck so sling can be attached for lifting crane.

### Outriggers:

Four hydraulic outriggers of box beam construction with direct-connected holding valves. Independent controls for each outrigger. Outrigger pad dimension: 11" x 16" (28cm x 41cm).

### Accessory Storage Box:

Storage box is 14" (35cm) deep x 10-1/2" (26cm) long x 36-1/2" (93cm) wide, located in front cargo deck.

## ELECTRICAL:

### 12 Volt System

#### Lighting Package:

One pair headlights with high and low beams, tail, brake and turn signal lights and back-up lights in rear, front turn signals and emergency flasher switch at operator's station.

#### Instrument Package:

Fuel gauge and hourmeter records hours only during actual engine operations. Also includes warning lights for low oil and transmission pressure, check engine, high coolant and transmission temperature, turn signals, high beams, hazard lights, parking brake and four-wheel drive.

#### Back-Up Alarm:

Provides pulsating sound when transmission is in reverse.

#### Outrigger Alarm System:

Two-tone alarm is activated when "outrigger down" controls are operated.

## HYDRAULIC SYSTEM:

Tandem pump, direct-driven by engine crankshaft, rated at 29 GPM (110 L/min) and 34 GPM (129 L/min) at rated RPM. Hydraulic oil tank capacity of 54 gallons (204 L).

## BOOM ASSEMBLY:

Three or four section boom assembly equipped with bearing pads, double-acting hydraulic cylinders with direct-connected holding valves and boom angle indicator on each side of boom.

## Boom Rotation:

Heavy-duty ball bearing rotation gear with external teeth. Rotation is powered by hydraulic motor and worm gear drive.

## Boom Hoist:

Turret mounted planetary gear hoist hydraulically powered with a bare drum line pull of 10,000 lbs. (4536 kg) at a line speed of 100 FPM (30 m/min). Includes downhaul weight, swivel hook and sheave block for 4-part line and 240 ft (73m) (2H) and 291 ft (89m) (3H) of 1/2" (13mm) hoist rope.

## Anti-Two-Block Device:

Prevents damage to hoist rope and/or crane components from pulling load hook against tip.

## Sheave Block, Four Part Line:

Double sheave block for 4-part line requirements.

## Rated Capacity Limiter:

Warns operator of impending overload with audible and visual signals. Prevents overloads by stopping boom functions that cause overloads.